

NPON_I0N0N u m un m w Lo m w l w r P

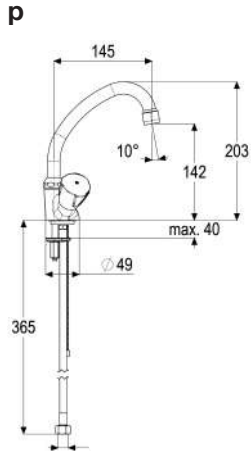

m

m 7
B:C- Wg Wb_p
T
i 8r HCAHtT

t ACBAAH8BAABA

a l
m 8 C
m 7

BEF

BEA
CAF

B:C-

an8

W p k ZXT
B:C- Wg Wb_p
T
i 8r HCAHtT

oi XLB

_ntg LEACAKCK0BAHED

I V b LACC CK8 E008EHEI 8 D 8FEKADI EE



r

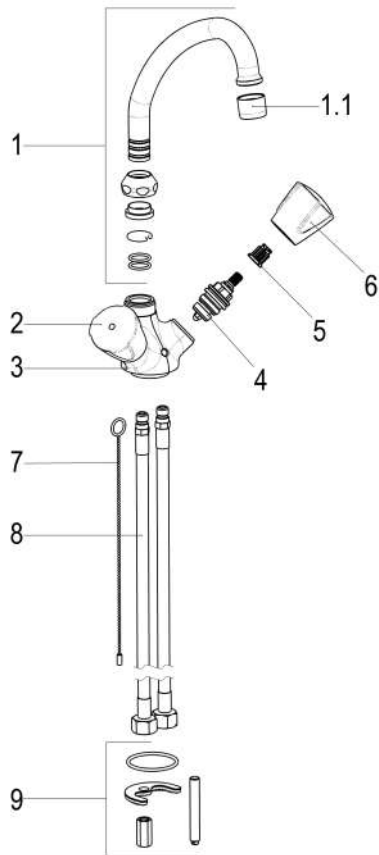

Lp

AB l a nglwXkl Tean8 i hnm
 AC l a aTgWeX nklTghg ahm
 AE aXTWi TkmB:C-
 AF l a WKnXgmUnl aTg_ Zhk
 aTgWeXI
 AG l a aTgWeX nklTghg VheW
 AH l a l eb VaTg
 AI l a ZeXr tleX ahI Xf BA r B8
 D:l -
 AK l a f hngntg_ dbnf l FHf f

m I L

t ABEAEB8AAABA
 t AAKAF8AAABA
 t AAAABE8AAAA
 t AAAEBD8AAAA
 t AAKAE8AAABA
 t AAACBK8AAABA
 t AAKBED8AAAA
 t AAAGAG8AAAA

p

l a maXkf h VhkgXk oTeoX
 Tei aT DAA

m I L

t AFFFG8AAABA

s

